

1)

Kirchhoff's first and second laws can be used to analyse any electrical circuit. They are a consequence of the conservation of physical quantities in the circuit.

(i) State Kirchhoff's **first** law and the physical quantity conserved.

.....
.....
..... [2]

(ii) State Kirchhoff's **second** law and the physical quantity conserved.

.....
.....
.....
..... [2]

2)

(a) State the difference between the directions of conventional current and electron flow.

.....
..... [1]

(b) Circle one or more of the combinations of units which could act as a unit for current.

$J s$ $C s^{-1}$ $V \Omega^{-1}$ $J C^{-1}$

[2]

(c) Fig. 1.1 shows a current I in a thick metal wire **X** connected to a longer thinner wire **Y** of the same metal as shown in Fig. 1.1.

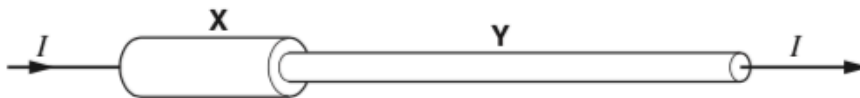

Fig. 1.1

(i) State why the current in **Y** must also be I .

.....
..... [1]

3)

(a) A 12V 36W lamp is lit to normal brightness using a 12V car battery of negligible internal resistance. The lamp is switched on for one hour (3600s). For the time of 1 hour, calculate

(i) the energy supplied by the battery

energy =J [2]

(ii) the charge passing through the lamp

charge =unit.....[3]

(iii) the total number of electrons passing through the lamp.

number of electrons = [2]

(b) The wires connecting the 36W lamp to the 12V battery are made of copper. They have a cross-sectional area of $1.1 \times 10^{-7} \text{ m}^2$. The current in the wire is 3.0A. The number n of free electrons per m^3 for copper is $8.0 \times 10^{28} \text{ m}^{-3}$.

(i) Describe what is meant by the term *mean drift velocity* of the electrons in the wire.

.....
.....
..... [2]

(ii) Calculate the mean drift velocity v of the electrons in this wire.

$v = \dots\dots\dots \text{ms}^{-1}$ [3]

[Total: 12]

4)

Fig. 1.1 shows the $I-V$ characteristic of a filament lamp.

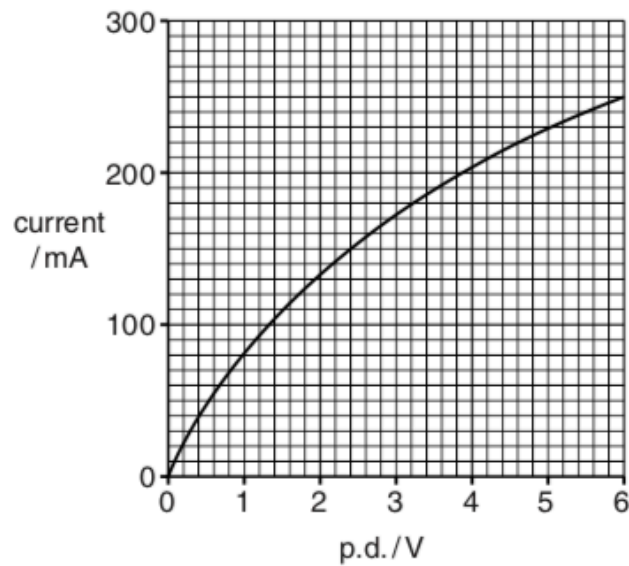

Fig. 1.1

(a) Explain how the graph of Fig. 1.1 shows that the filament lamp does not obey Ohm's law.

.....

.....

..... [2]

(b) You are to carry out an experiment to obtain the $I-V$ characteristic shown in Fig. 1.1.

(i) Draw a suitable circuit diagram for your experiment in the space below. [2]

(ii) Describe how you would carry out the experiment.



In your answer you should make clear how you make the measurements to obtain the data for the characteristic.

.....
.....
.....
.....
.....
..... [3]

(c) The lamp is connected in **parallel** with a resistor of resistance 20Ω to a 6.0V d.c. supply of negligible internal resistance. Use Fig. 1.1 to calculate the current I_p drawn from the supply.

$$I_p = \dots\dots\dots \text{ A [3]}$$

(d) The circuit is rearranged with the lamp connected in **series** with the 20Ω resistor to the same 6.0V supply.

(i) On Fig. 1.1 draw the $I-V$ characteristic of the resistor. [1]

(ii) Use your answer to (i) and Fig. 1.1 to determine the current I_S drawn from the supply. Explain your method.

$$I_S = \dots\dots\dots \text{ A [3]}$$

[Total: 14]

5)

A set of Christmas tree lights consists of 40 identical filament lamps connected in series across a supply of 240V.

(a) Define *resistance*.

.....
 [1]

(b) Each lamp when lit normally carries a current of 250 mA.

Calculate

(i) the potential difference V across a lamp

$V = \dots\dots\dots V$ [1]

(ii) the resistance R of a lamp.

$R = \dots\dots\dots \Omega$ [2]

(c) Fig. 1.1 shows the results of an experiment to find how the current in one of the lamps varies with the potential difference across it.

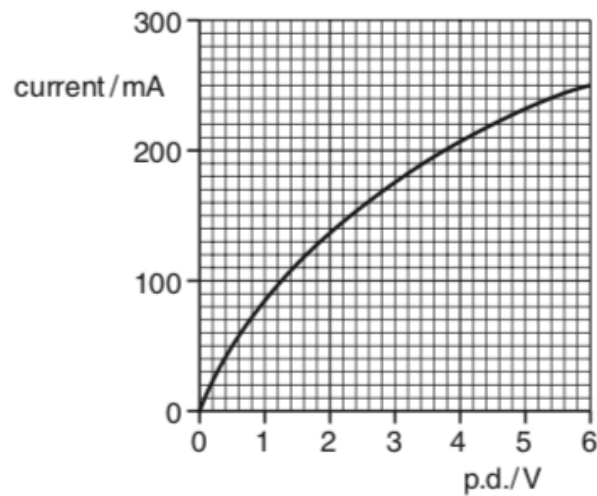

(i) Draw a diagram of the circuit that you would use to perform this experiment.

[3]

(ii) The resistance of the lamp when at room temperature is 10Ω . Using Fig. 1.1 sketch a graph on the axes of Fig. 1.2 of the variation of resistance R with current for the lamp.

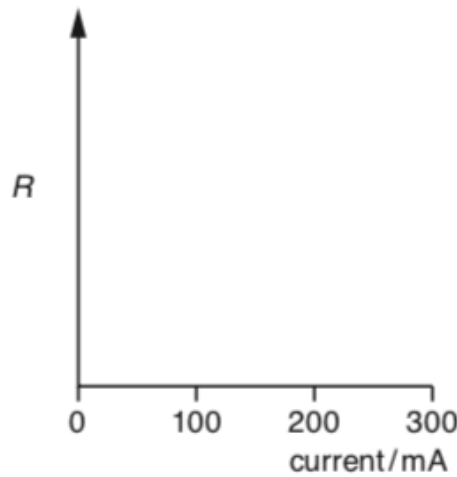

Fig. 1.2

[2]

(iii) Explain why the resistance of the lamp varies as shown by the graph you have drawn on Fig. 1.2.

.....

.....

.....

..... [2]

(d) In an alternative design for the set of Christmas tree lights, a 100Ω resistor is connected in parallel with each lamp.

(i) Describe what happens to the brightness in each set of lamps when one lamp filament burns out.

1 *original set*
..... [1]

2 *alternative set*
..... [1]

(ii) Calculate the current drawn from the supply for the alternative set of lamps with all lamps working.

current = A [3]

[Total: 16]

(ii) Calculate the resistance of the LED

1 at 1.2V

resistance = Ω [1]

2 at 1.9V.

resistance = Ω [2]

(b) In order to carry out an investigation to determine the I - V characteristic of an LED a student connects the circuit shown in Fig. 4.2.

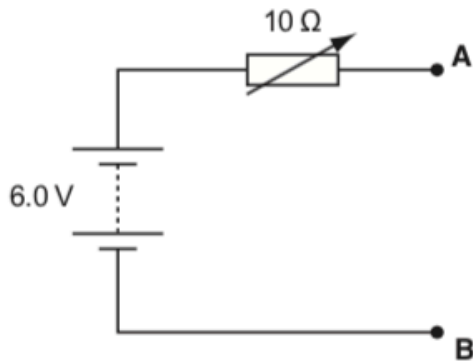

Fig. 4.2

On Fig. 4.2 add an LED with a 100 Ω resistor in series, an ammeter and a voltmeter to complete the circuit between terminals **A** and **B**. [3]

(c) When designing a circuit which includes an LED, it is normal practice to connect a resistor in series with the LED, in this case 100 Ω . Suggest and explain the purpose of this resistor.

.....
.....
..... [2]

- (d) Another student uses the $10\ \Omega$ variable resistor as a potentiometer (potential divider) as shown in Fig. 4.3. The rest of the circuit is then completed between terminals **A** and **B** as for Fig. 4.2 in (b).

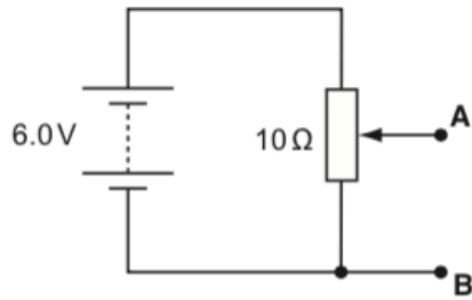

Fig. 4.3

Explain why the circuit of Fig. 4.3 is more suitable for obtaining the I - V characteristic of the LED than the circuit of Fig. 4.2.

.....

.....

.....

.....

.....

..... [3]

[Total: 16]

7)

(a) Two filament lamps are described as being 230V, 25W and 230V, 60W.

(i) Describe what is meant by '230V, 25W' for a lamp.

.....
.....
.....
..... [2]

(ii) Calculate the resistance of the 25W lamp when connected to a 230V supply.

resistance = Ω [2]

(iii) Each of the two lamps is connected across a 230V supply. Explain which lamp has the greater current.

.....
.....
.....
..... [2]

(iv) Both lamps are connected in parallel across the 230V supply. The resistance of the 60W lamp in the circuit is 880Ω . Calculate

1 the total resistance R across the supply

$R =$ Ω

2 the current I drawn from the supply.

$I =$ A [4]

- (b) The 60W filament lamp is connected to a 6.0V battery. The resistance of the lamp in this circuit is 70Ω . Explain why this value differs from the value given in (a)(iv) when the lamp is connected to the 230V supply.



In your answer, you should make clear how your explanation links with the observations.

.....
.....
.....
.....
..... [2]

- (c) By mistake a householder leaves a 60W filament lamp switched on overnight for a period of 8.0 hours.

The cost of 1.0 kilowatt-hour of electricity is 21 pence.

- (i) Define the *kilowatt-hour* (kWh).

.....
.....
..... [1]

- (ii) Calculate the cost of this mistake to the householder.

cost = pence [2]

[Total: 15]

8)

Two 6.0V torches produce similar light intensities. The light source of one is a single filament lamp and of the other is a combination of four light-emitting diodes (LEDs). Fig. 1.1 shows the I - V characteristics of the filament lamp and **one** LED.

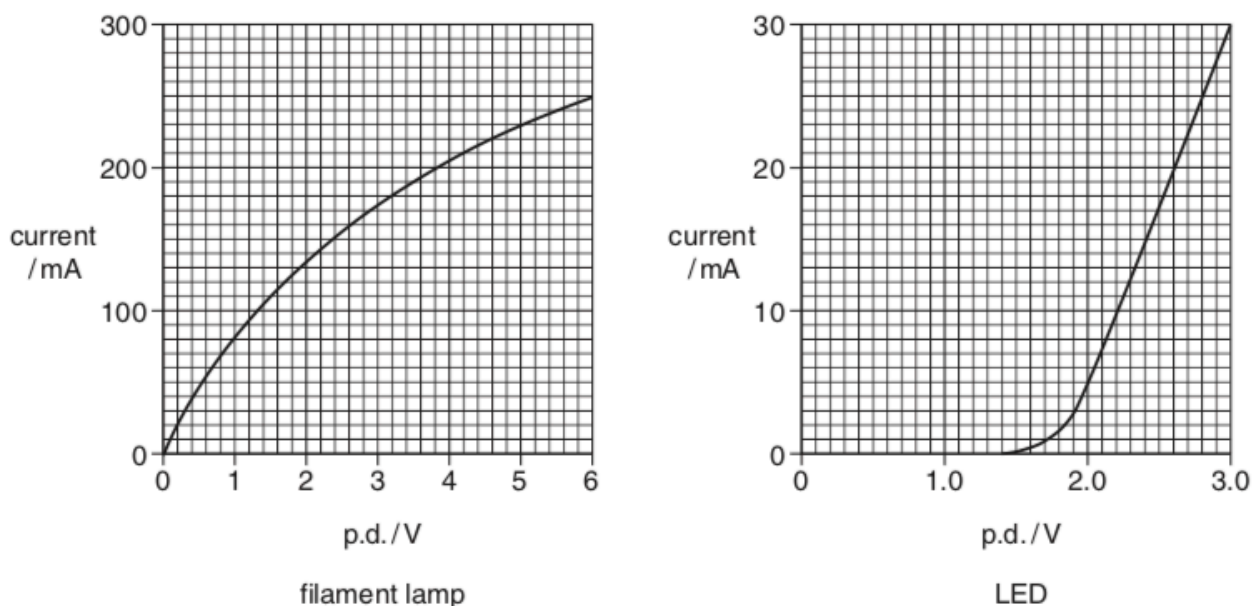

Fig. 1.1

(a) (i) Describe how the resistance of the filament lamp at 6.0V can be determined from its I - V characteristic.

.....
 [2]

(ii) State how the I - V characteristics show that the filament lamp and the LED do not obey Ohm's law.

.....
 [1]

(b) When at normal brightness the current in the filament lamp is 0.25A at a p.d. of 6.0V.

(i) Calculate the charge Q passing through the filament each second.

$Q = \dots\dots\dots$ C [1]

(ii) Calculate the energy drawn from the battery each second.

energy = $\dots\dots\dots$ J [1]

- (iii) The battery is able to keep the lamp lit for 4 hours. Estimate the energy stored in the battery.

energy stored = J [2]

- (c) The LEDs in the LED torch are connected in pairs across the 6.0V battery and switch so that the potential difference across each of the four LEDs is 3.0V.

- (i) Define the term *potential difference*.

.....
..... [2]

- (ii) Use Fig. 1.1 to determine the current through each LED.

current = mA [1]

- (iii) Show that the power drawn from the battery in the LED torch is 0.36W.

[2]

- (iv) Sketch a circuit diagram showing how the battery, the four LEDs and the switch are connected in the torch.

[3]

- (d) Suggest one advantage of using LEDs rather than a filament lamp in a torch.

.....
..... [1]

[Total: 16]

- (b) A circuit is set up to obtain the $I-V$ characteristic shown in Fig. 2.1. It consists of a variable $0-6.0\text{V}$ d.c. power supply connected in **series** to a $100\ \Omega$ resistor and the LED. Fig. 2.2 shows the variable supply. Draw the resistor, LED and suitable meters on the diagram between terminals **X** and **Y** to complete the circuit required for the experiment. [4]

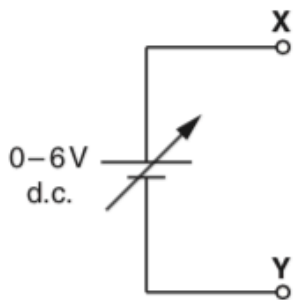

Fig. 2.2

- (c) One or more LEDs are often used in places where, in the past, a filament lamp would have been used.
Give **one** example of such a situation.
Explain **one** advantage of using LEDs in place of a filament lamp in the situation you have chosen.

.....

.....

.....

.....

.....

.....

..... [2]

[Total: 12]

10)

Fig. 1.1 shows the I - V characteristic of a 6.0V 1.5W filament lamp.

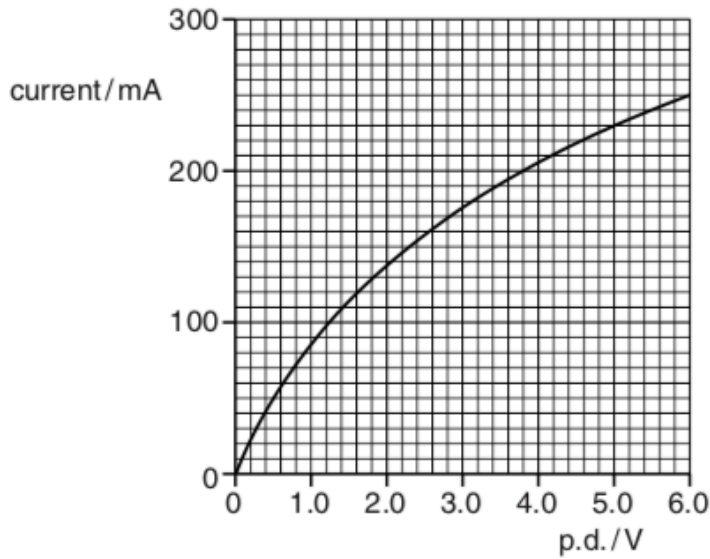

Fig. 1.1

(a) (i) State how Fig. 1.1 shows that the filament lamp does not obey Ohm's law.

.....
 [1]

(ii) Explain how Fig. 1.1 shows that the resistance of the filament lamp is about 10Ω when the current is between zero and 50mA.

[2]

(iii) Explain why the resistance of the filament lamp is much larger (about 25Ω) at 6.0V.

.....

 [2]

11)

Fig. 4.1 shows the *I-V* characteristic of a blue light-emitting diode (LED).

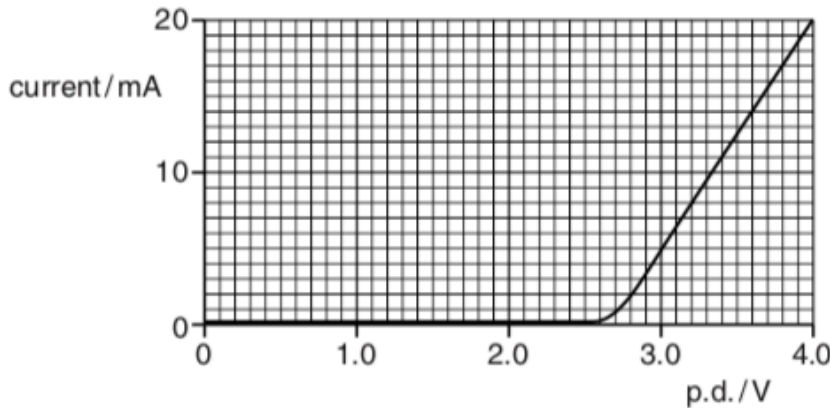

Fig. 4.1

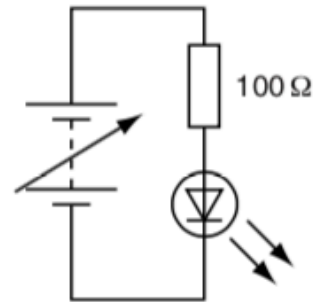

Fig. 4.2

(a) (i) The data for plotting the *I-V* characteristic is collected using the components shown in Fig. 4.2. By drawing on Fig. 4.2 complete the circuit showing how you would connect the two meters needed to collect these data. [1]

(ii) When the current in the circuit of Fig. 4.2 is 20mA calculate the terminal potential difference across the supply.

terminal p.d. = V [3]

(b) The energy of each photon emitted by the LED comes from an electron passing through the LED. The energy of each blue photon emitted by the LED is 4.1×10^{-19} J.

(i) Calculate the energy of a blue photon in electron volts.

energy = eV [1]

(ii) Explain how your answer to (i) is related to the shape of the curve in Fig. 4.1.

.....

 [2]

(c) Calculate for a current of 20 mA

(i) the number n of electrons passing through the LED per second

$$n = \dots\dots\dots \text{ s}^{-1} \text{ [2]}$$

(ii) the total energy of the light emitted per second

$$\text{energy per second} = \dots\dots\dots \text{ J s}^{-1} \text{ [2]}$$

(iii) the efficiency of the LED in transforming electrical energy into light energy.

$$\text{efficiency} = \dots\dots\dots \text{ [2]}$$

(d) The energy of a photon emitted by a red LED is 2.0 eV. The current in this LED is 20 mA when the p.d. across it is 3.4 V. Draw the I - V characteristic of this LED on Fig. 4.1. [2]

[Total: 15]

12)

Fig. 2.1 shows the I - V characteristic of a light-emitting diode (LED) which is designed to light normally at a current of 30 mA.

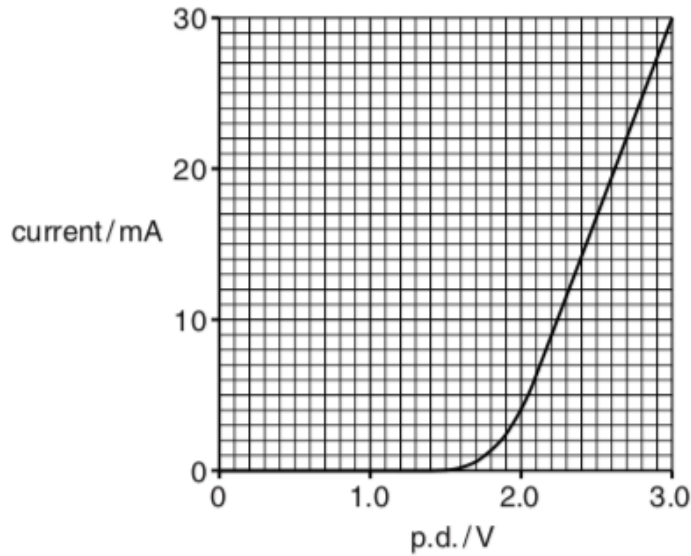

Fig. 2.1

(a) (i) On Fig. 2.1 draw the I - V characteristic of a fixed resistor of resistance $67\ \Omega$. [2]

(ii) Explain how the I - V characteristics show that the resistor obeys Ohm's law but the LED does not.

.....

.....

.....

..... [2]

(b) The LED and $67\ \Omega$ resistor are connected in **series** to a 5.0V d.c. supply of negligible internal resistance.

(i) Show that the LED lights normally, i.e. with a current of 30 mA.

[3]

(ii) Calculate

1 the charge Q passing through the LED each second

$Q = \dots\dots\dots$ C [1]

2 the energy required to light the LED each second

energy = $\dots\dots\dots$ J [2]

3 the energy dissipated in the resistor each second.

energy = $\dots\dots\dots$ J [2]

- (iii) Seven of these LEDs, each with its 67Ω series resistor, are arranged in a unit as shown in Fig. 2.2 to display any number from 0 to 9.



Fig. 2.2

Three of these units enable numbers up to 999 to be displayed. The three number display is connected to the 5.0V supply so that all the LED-resistor combinations are in parallel. Each three number display is provided with a fuse.

Circle the most suitable value for the fuse from the list below and give a reason for your choice.

- 50mA 500mA 1.0 A 3.0 A

.....
.....
.....
..... [2]

- (c) Give **one** other example where LEDs are now commonly used. Suggest **one** advantage of using LEDs in place of filament lamps.

.....
.....
.....
..... [2]